

Dimensions of the FP 30 / 38 E-Q REFERENCE Quality Inspection Projector

[mm / inches]

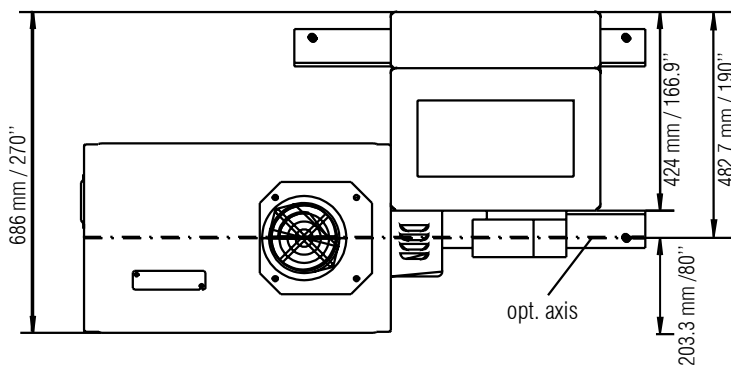
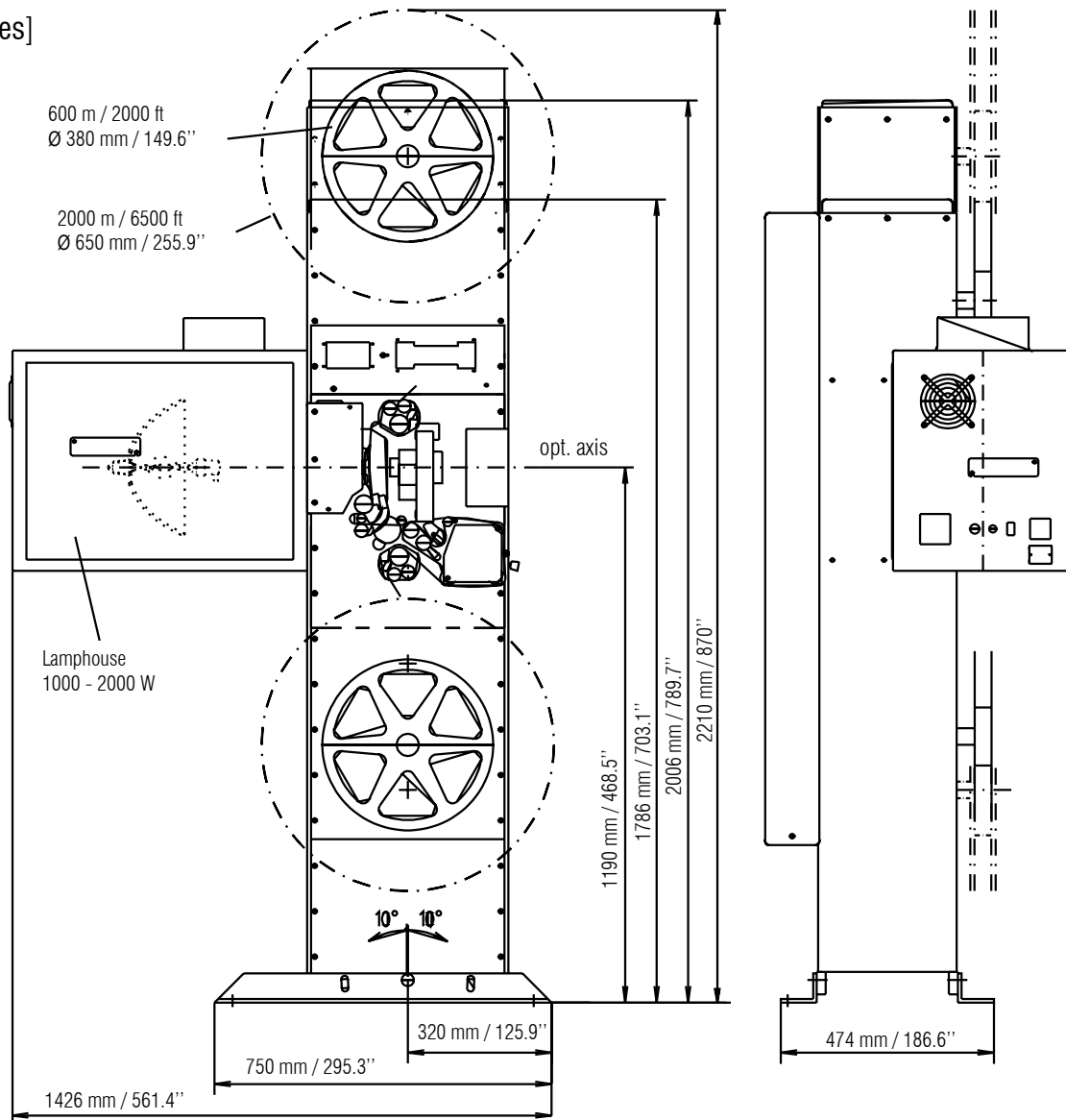

See the Difference

Kinoton GMBH

E-mail: welcome@kinoton.de
 Tel +49 (0) 89 / 89 44 46-0
 Fax +49 (0) 89 / 8 40 20 02
 Industriestrasse 20a
 82110 Germering